

➤ **SMART Digital
DDA – DDC – DDE**

Modular.
Simple.
Intelligent.



SMART Digital

We're breaking the barriers of conventional dosing

A new era of dosing technology

Chemistry in water treatment, water and wastewater recycling and disinfection has experienced a huge development over recent years, and this poses a challenge for today's dosing technology. More and more complex applications require intelligent dosing pumps with new drives or new control and adjustment mechanisms to simplify the operators' job.

SMART Digital dosing pumps meet these challenges offering state-of-the-art drive technology, new dimensions of user-comfort and intelligent flow control. These features ensure extremely reliable, cost-effective and high-precision processes at an optimum price-performance ratio.

Reliable processes ✓
Unique user-friendliness ✓
Simple Plug'n'Play ✓

Designed to save costs and to protect the environment

In general, the investment for a dosing pump installation is low compared to its life cycle costs. Low operation costs and longer maintenance intervals combined with an extremely high dosing accuracy make SMART Digital the perfect partner for:

- › Saving chemicals with high dosing accuracy and FlowControl
- › Saving energy with latest drive technology and improved electronics
- › Saving maintenance costs thanks to the universal chemical resistance of the full-PTFE diaphragm and Digital Dosing™
- › Saving natural resources with new composite materials and sustainable production processes

Optimal cost control ✓
Environmentally-friendly ✓



GRUNDFOS DOSING AND DISINFECTION

Processes

SMART Digital can be used in a wide range of processes...

- › Disinfection
- › pH-adjustment
- › Chemical dosing
- › Cleaning-in-place
- › Biocides
- › Coagulation
- › Precipitation/Flocculation
- › Filtration
- › Reverse osmosis

Application areas

... within a vast field of application areas:

- › Ground water
- › Surface water
- › Drinking water
- › Process water
- › Recreational water
- › Recycle & reuse



DDA



GRUNDFOS
ALDOS

SMART Digital The perfect system

Simplicity

Precise and easy setup. Intuitive user interface. **Simple handling and perfect overview and control even from a distance – it's always easy to handle our SMART Digital!**

- › Intuitive and self-explanatory menu
- › Click wheel (turn-and-push knob)
- › Big graphical LCD with four color “traffic light” concept
- › More than 25 languages



Intelligent and intuitive handling saves time and cost – ensuring a seamless integration in all workflows ✓

Modularity

Requirements change, demands grow, and capacities vary – **SMART Digital fits into every environment and situation!**

- › Turn-down ratio up to 3000:1 with a dosing spectrum of 0.0007 – 86 gallons per hour
- › Click-stop mounting plate for quick and variable installation
- › Control cube can be placed in three positions (left, right, front)
- › Using switch-mode power supply, the SMART Digital model DDA is independent from regional voltages

Highest performance in all operating conditions and a flexible concept you can always rely on ✓



MODULARITY
SIMPLICITY
FLOW INTELLIGENCE

SMART Digital

High performance is our standard

Flow Intelligence

Full control under all conditions. **Highest process reliability – at any time with SMART Digital!**

- › FlowControl with selective fault diagnosis
- › Pressure monitoring
- › Flow measurement
- › AutoFlowAdapt

Groundbreaking flow intelligence guarantees highest process reliability ✓



Digital Dosing™

The SMART Digital generation DDA, DDC and DDE with powerful variable-speed stepper motors bring state-of-the-art technology to perfection.

Combined expert knowledge and the new patented solutions set future standards. Traditional technologies such as stroke length/stroke frequency adjustment with synchronous motor or solenoid drive become a thing of the past.

- › Powerful variable-speed stepper motor
- › Internal stroke speed control
- › Turn-down ratio up to 3000:1
- › Always full stroke length – even at small flow rates
- › Smooth, continuous dosing
- › Optimal for degassing liquids
- › SlowMode function for high-viscosity liquids

New patented solutions set future standards ✓

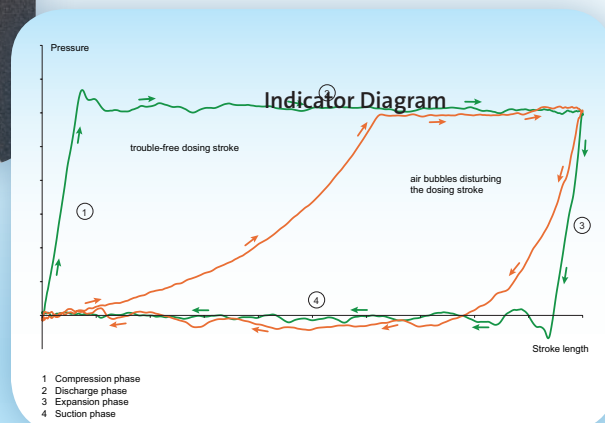

MODULARITY
SIMPLICITY
FLOW INTELLIGENCE

GRUNDFOS DOSING AND DISINFECTION

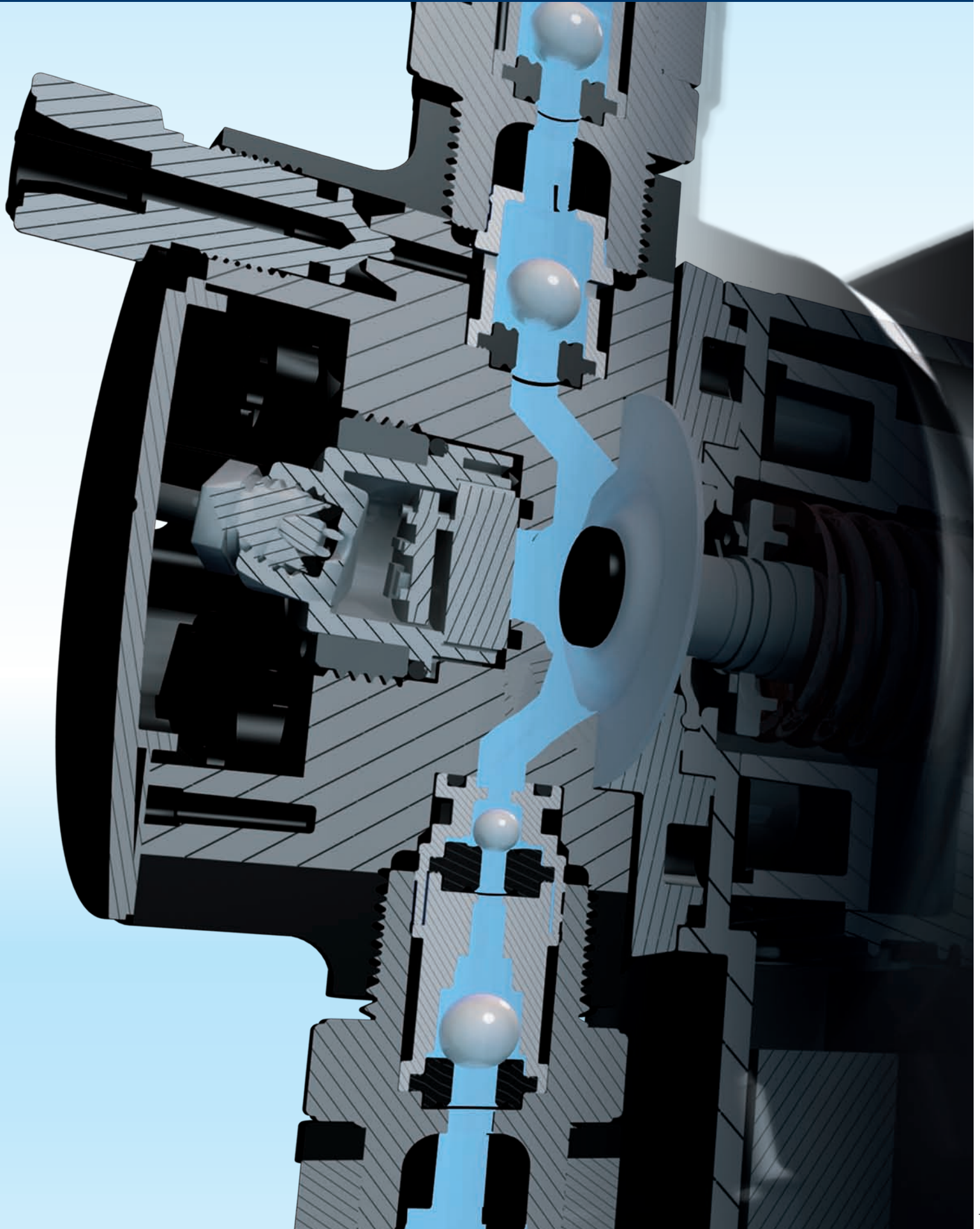

SMART Digital DDA, DDC, DDE

Perfect solutions for vast market segments

DDA

This high-end DDA pump range is designed for complex and demanding applications. Whether degassing liquids, flow rates down to 0.0007 gph or advanced process control are required, this pump offers the perfect solution:

- › Max. 8 gph and 232 psi
- › Turn-down ratio 3000:1 (7.5-16) or 1000:1
- › FlowControl with selective fault diagnosis
- › Integrated flow measurement
- › AutoFlowAdapt
- › Auto deaeration also during pump standby
- › Batch modes (timer- or pulse-based)
- › Optional E-box for Profibus DP integration

Please see next page for further details.

DDC

The DDC pump range is the optimum solution for common applications. The easy-to-use interface with the click wheel makes the setup and operation as easy as your car radio system:

- › Max. 4 gph and 150 psi
- › Turn-down ratio 1000:1
- › Graphical LC display (LCD) backlit in different colors
- › More than 25 languages
- › Standard operation modes, e.g. pulse and analog
- › SlowMode for high viscosity liquids
- › 2 integrated relay outputs

Please see next page for further details.

DDE

The DDE offers Digital Dosing with basic functions even for a low budget for easier applications. Now just two pump models cover a range where 12 or more were needed in the past:

- › Max. 4 gph and 150 psi
- › Turn-down ratio 1000:1
- › Smooth continuous dosing
- › Always 100% suction stroke
- › Capacity setting 0.1-100%
- › Simple pulse operation mode
- › External stop and empty tank alarm

Please see next page for further details.

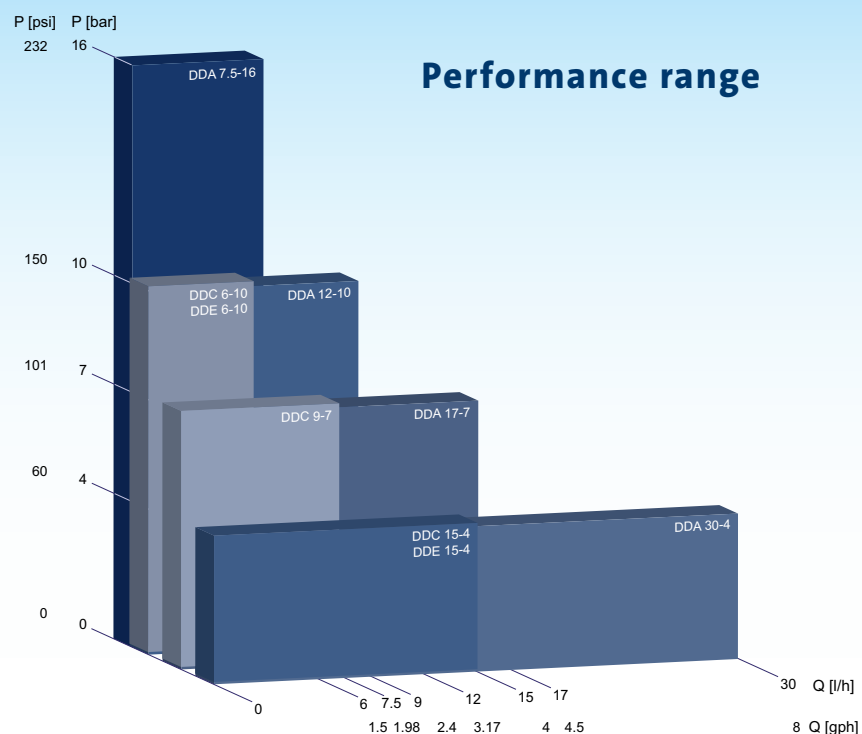

GRUNDFOS DOSING AND DISINFECTION

Overview of functions

	DDA			DDC		DDE	
	FCM	FC	AR	AR	A	P	B
General							
Digital Dosing: Internal stroke speed and frequency control	●	●	●	●	●	●	●
Mounting plate (basic / wall mounting)	●	●	●	●	●	●	●
Supply voltage 100-240 V, 50-60 Hz	●	●	●	●	●	●	●
Enclosure class IP 65	●	●	●	●	●	●	●
Control panel							
Control cube mountable in three positions: front, left, right	●	●	●	●	●		
Control panel position: front-fitted						●	●
Transparent protective cover for control elements	●	●	●	●	●		
Capacity setting in millilitres, litres or US-gallons	●	●	●	●	●		
Graphical display with background light in four colours for status indication: white, green, yellow, red	●	●	●	●	●		
Plain-text menu in different languages	●	●	●	●	●		
Turn-and-push knob (click wheel) for easy navigation	●	●	●	●	●		
Capacity adjustment knob (0.1 - 100%)						●	●
Start / Stop key	●	●	●	●	●		
100% key (deaeration)	●	●	●	●	●	●	
Operation mode switch (manual / pulse)						●	
Operation modes							
Manual speed control	●	●	●	●	●	●	●
Pulse control in ml/pulse	●	●	●	●	●		
Pulse control (1:n)						●	
Analog control 0/4-20 mA	●	●	●	●			
Batch control (pulse-based)	●	●	●				
Dosing timer cycle	●	●	●				
Dosing timer week	●	●	●				
Fieldbus control	●	●	●				
Functions							
Auto deaeration also during pump standby	●	●	●				
FlowControl system with selective fault diagnosis	●	●					
Pressure monitoring (min / max)	●	●					
Flow measurement	●						
AutoFlowAdapt	●						
SlowMode (anti-cavitation)	●	●	●	●	●		
Calibration mode	●	●	●	●	●		
Scaling of analog input	●	●	●				
Service information display	●	●	●	●	●		
Relay setting: alarm, warning, stroke signal, pump dosing	●	●	●	●			
Relay setting (additionally): timer cycle, timer week	●	●	●				
Inputs/outputs							
Input for external stop	●	●	●	●	●	●	
Input for pulse control	●	●	●	●	●	●	
Input for analog 0/4-20 mA control	●	●	●	●			
Input for low-level signal	●	●	●	●	●		
Input for empty tank signal	●	●	●	●	●	●	
Output relay (2 relays)	●	●	●	●			
Output analog 0/4-20 mA	●	●	●				
Input / Output for GeniBus	●	●	●				
Input / Output for E-box (Profibus DP or additional alarm relays)	●	●	●				

SMART Digital Accessories and Service

E-Box Profibus DP

With the additional E-Box module, the pump can be easily integrated in a Profibus DP network. This enables remote monitoring and setting via the fieldbus system. Just click the E-box in between the DDA pump and the mounting plate. With the plug and play solution, DDA pumps can also be easily retrofitted.



General pump accessories

A wide range of accessories is available for SMART Digital pumps:

- › Installation kit including foot valve, injection unit and hose
- › Multi-function valve (PVDF)
- › Rigid suction lance (PE, PVDF) with low level and empty tank signal
- › Foot valve for flexible suction line (PE, PVDF, stainless steel)
- › Injection unit (PP, PVC, PVDF, stainless steel) in different designs
- › Hose in PVC, PE, ETFE in different sizes
- › Signal cables for all inputs and outputs

All components have been especially designed for and adjusted to the new SMART Digital pumps.

Only original SMART accessories can guarantee optimum dosing results.



Service

Service kits are available for PP, PVC, PVDF and stainless steel:

- › Complete dosing head kit
- › Valves and diaphragm kit
- › Valve kit
- › Diaphragm kit

Please see service catalog for further service kits and details.

SMART Digital pumps have outstandingly long maintenance intervals.

Wear and tear parts which have been in contact with the media need only be replaced after 8000 operating hours (or after two years at the latest).

Shorter intervals might be necessary for highly-abrasive media.

ALL THE INFORMATION YOU NEED IS ONLINE

Grundfos WebCAPS is an online product selection tool, but it offers much more. The site compiles all the product-related information you could ever need.

What you can find in WebCAPS

Catalog – includes all products available in your region, complete with technical information, drawings, descriptions, performance curves, etc.

Literature – find everything from data booklets through installation & operating instructions to product brochures.

Service – the place to find service instructions (including video tutorials), service parts lists, assembly drawings, etc.

Sizing – enter your system requirements for instant recommendations. Includes life cycle cost calculations.

Replacement – enter the make and model of your old pump for an instant replacement recommendation.

CAD drawings – download DXF and DWG files as required.

For offline use, WinCAPS is a CD-ROM version of WebCAPS. Contact Grundfos to order.



Our new SMART Digital pump family can be easily installed in various positions due to its modular construction. With its user-friendly display and menu-structure, the pump is easy to operate. The integrated flow intelligence assures safe and continuous processes, making it an absolutely reliable pump.

On top of that, you save TIME and MONEY when opting for SMART Digital.

You save TIME:

- > Easy commissioning and service due to the click-stop mounting plate
- > Self-explanatory user-interface
- > Plain-text display for failure indication: no need for time-consuming fault analysis
- > Quick commissioning without reading the I/O
- > Easy process control thanks to the intelligent flow management functions

You save MONEY:

- > No additional installation parts needed due to the click-stop mounting plate
- > High accuracy saves chemicals
- > The required target flow is always achieved due to the AutoFlowAdapt, FlowControl and flow measurement functions; additional monitoring and control devices are made redundant
- > Intelligent flow management prevents expensive process breakdowns

U.S.A.
GRUNDFOS Pumps Corporation
17100 West 118th Terrace
Olathe, Kansas 66061
Phone: (913) 227-3400
Telefax: (913) 227-3500

Canada
GRUNDFOS Canada Inc.
2941 Brighton Road
Oakville, Ontario
L6H 6C9
Phone: (905) 829-9533/Telefax: (905) 829-9512

Mexico
Bombas GRUNDFOS de Mexico S.A. de C.V.
Boulevard TLC No. 15
Parque Industrial Stiva Aeropuerto
C.P. 66600 Apodaca, N.L. Mexico
Phone: 011-52-81-8144 4000/Telefax: 011-52-81-8144 4010

L-SD-SI-01 • 09/10 (US)

www.grundfos.us/industry

The name Grundfos, the Grundfos logo, and the payoff Be-Think-Innovate are registered trademarks owned by Grundfos Management A/S or Grundfos A/S, Denmark. All rights reserved worldwide.



GRUNDFOS 